

Oskarshamn site investigation

Control of microorganism content in flushing water used for drilling of KLX11A

Karsten Pedersen, Microbial Analytics Sweden AB

January 2006

Keywords: ATP, Bacteria, Disinfection, Laxemar, Simpevarp, Ultra violet light.

This report concerns a study which was conducted for SKB. The conclusions and viewpoints presented in the report are those of the author and do not necessarily coincide with those of the client.

A pdf version of this document can be downloaded from www.skb.se

Abstract

A system for disinfection of flushing water and continuous dosage of tracer for drilling fluids has been developed. It comprises an ultra violet (UV) radiation unit and a flow controlled dosing pump for a drill water tracer attached on line in the flushing water system.

This activity aimed to control the effect from cleaning on the drill water system during drilling of KLX11A and to determine the amount of microorganisms being introduced in the borehole during drilling. The second aim was to control the disinfection efficiency of the UV-unit during drilling. The drill water was extracted from HLX28.

The numbers of cultivable cells in the flushing water was in most cases below the acceptable limit, i.e. 1,000 cells ml⁻¹, in December 2005 during drilling of KLX11A. At upstart of the drilling in January of KLX11A, the drill water system was cleaned. The numbers of cultivable cells were well below the limit of acceptance after this cleaning.

The ATP concentrations were about similar at both sampling occasions. ATP correlates with the total number of bacteria. It is consequently a measure of both contaminating microorganisms in the drill water system and naturally occurring cells in the drill water well. As the ATP levels were comparable throughout 15 out of 16 analyses, it can be concluded that the drill water system did not add large amounts of contaminating cells to the drill water.

There was no clear effect from the UV unit on cultivable numbers and the ATP. In one case during January, high number of ATP was detected after the uranin dosage point.

In conclusion, it is possible to keep flushing water systems clean. The numbers obtained after cleaning in January were acceptable.

Sammanfattning

Ett system för anti-mikrobiell behandling av spolvatten för borring har utvecklats. Systemet omfattar en UV-enhet samt en flödeskontrollerad dosering av spårämne på spolvattensystemet ”on line”.

Denna aktivitet syftade på att kontrollera effektiviteten i rengöringsprocedurerna under borring av KLX11A samt att fastställa mängden mikroorganismer som introducerades till borrhålet i samband med borringen. Ett ytterligare syfte var att kontrollera desinfektionsförmågan hos UV-enheten.

Bakteriehalten i spolvattnet låg i de flesta fall under nivån för ej acceptabelt dvs under 1 000 celler ml⁻¹, under borring av KLX11A i december 2005. Vid uppstart av borringen i januari 2006 rengjordes spolvattensystemet. Antalet odlingsbara bakterier låg väl under gränsen för ej acceptabelt.

ATP concentrationerna var genomgående samma vid båda provtagningstillfällena i december och januari. ATP korrelerar med totalantalet bakterier. Följdaktligen är ATP ett mått på summan av mikroorganismer som tillförs från orenheter i spolvattensystemet och de mikroorganismer som förekommer naturligt i borrhålet från borrhålets brunnen (HLX28). Eftersom ATP nivåerna var jämförbara i 15 av totalt 16 analyser kan man dra följande slutsats: Spolvattensystemet tillförde inte några detekterbara mängder kontaminerande mikroorganismer till spolvattnet.

Det fanns ingen tydlig effekt från UV-enheten på antalet odlingsbara bakterier och ATP nivåerna. I ett fall, i januari, detekterades en hög ATP halt efter uranindoseringen.

Sammanfattningsvis kan det konstateras att det är möjligt att hålla spolvattnet på en acceptabel nivå vad gäller mikrobinnehåll. Antalet odlingsbara bakterier låg väl under gränsen för ej acceptabelt efter rengöring.

Contents

1	Introduction	7
2	Objective and scope	9
3	Equipment	11
3.1	Description of equipment/interpretation tools	11
3.1.1	Sampling	11
3.1.2	Number of cultivable cells	11
3.1.3	Analysis of ATP	12
4	Execution	13
4.1	General	13
4.2	Preparations	13
4.3	Data handling/post processing	13
4.4	Analyses and interpretations	13
4.5	Nonconformities	14
5	Results	15
5.1	KLX11A drilling	15
6	Conclusions	19
	References	20

1 Introduction

A system for disinfection of flushing water and continuous dosage of tracer for drilling fluids has been developed (Figure 1-1). It comprises an ultra violet (UV) radiation unit and a flow controlled uranin dosing pump attached on line in the flushing water system. It is known since earlier investigations that flushing water may introduce large number of contaminating microbes into the aquifers /Pedersen et al. 1997/. This should be avoided because it may cause errors in the succeeding investigations of geochemistry and microbiology. The basic procedure to achieve a microbiologically approved flushing water system is to clean the drillwater system frequently. The UV-lamp should be kept clean and its proper efficiency should be continuously controlled. The uranin tank and mixture must be kept free from microbes. This is because some bacteria can grow on and degrade this tracer.

The drill water system was sampled at four points (Figure 1-1). The first sample (1) was taken directly after the drill water was pumped up from the borehole. This point gives the microbial content in the borehole and the hygienic status of the borehole pump. The second sample point was located after the UV-unit (2). This point should demonstrate the efficiency of the UV-unit and hygiene. The numbers of cultivable cells should here be significantly lower compared to the first sampling point. The third sample was taken directly after the uranin dosage system (3). The last point (4) was located in the drilling machine. This point shows the hygienic status of the drill rig and the storage tank.

The results from a previous drill water investigation in Oskarshamn during drilling of KSH03 have been reported /Kalmus 2004/, KAV04 and KLX03 /Pedersen 2005a/ and KLX08 /Pedersen 2005b/. This document reports the results gained during drilling of KLX11A. The system was sampled 2005-12-21 and 2006-01-11. The drill water source was HLX28. The results have been reported to the SICADA database.

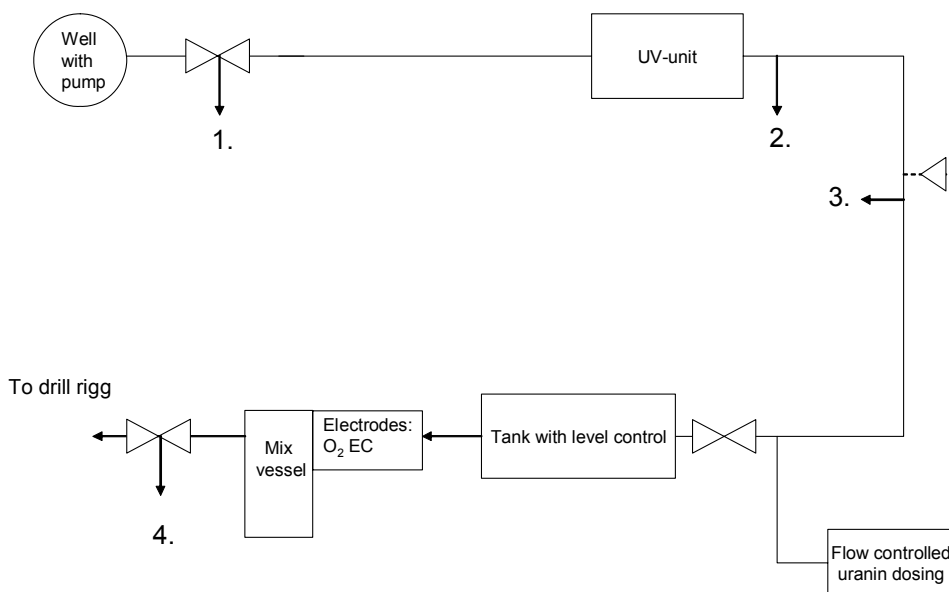

Figure 1-1. Schematic drawing of the drill water system.

2 Objective and scope

A washing/cleaning procedure and a disinfection UV-unit have been introduced to minimize the amount of microbes in the flushing water system during drilling. This activity aimed at:

1. Control of the effect from cleaning of the drill water system during drilling of KLX11A. The performance of the flushing water treatment with reference to its ability to reduce potentially occurring microbes in the flushing water was analyzed.
2. Control of the disinfection efficiency of the UV-unit.
3. Control of microorganism content directly after the uranin dosage point.
4. Determination of the amount of microorganisms possibly being introduced in the borehole during drilling.

3 Equipment

3.1 Description of equipment/interpretation tools

3.1.1 Sampling

Sampling was performed in 1 L sterile glass bottles on 4 positions in the drill water line according to Figure 1-1. Sampling was repeated once to understand the total variability over time included in the sampled water (short term fluctuations in water quality), and the sampling procedure.

3.1.2 Number of cultivable cells

A plate count medium was constructed based on earlier work /Pedersen and Ekendahl 1990, Pedersen et al 1997/. It was prepared as follows: Per litre of medium: peptone, 0.5 g; yeast extract, 0.5 g; starch (soluble), 0.25 g; sodium acetate, 0.25 g; CaCl₂ x 2H₂O, 0.2 g; K₂HPO₄, 0.1 g; NaCl, 10 g, trace element solution according to Table 3-1, 1 ml (Non-chelated trace element mixture); agar, 15 g. pH was adjusted to 7.0. The medium was autoclaved at 121 °C for 20 minutes, cooled to 50 °C and poured in 15 ml portions in sterile Petri dishes. The produced agar plates were allowed to dry for about 12 hours and then put in plastic bags until use.

Dilution tubes were prepared as follows: 18 ml Hungate tubes were supplied with 10 ml the following solution and autoclaved: NaCl, 10 g; K₂HPO₄, 0.1 g.

The samples in Table 4-1 were diluted in 10 times increments. From each dilution tube, 0.1 ml was spread with sterile glass loops on an agar plate produced as described above.

Table 3-1. Non-chelated trace element solution.

Component	Amount
Double distilled H ₂ O	987 mL
HCl (25% = 7.7M)	12.5 mL
FeSO ₄ *7H ₂ O	2.1 g
H ₃ BO ₃	30 mg
MnCl ₂ *4H ₂ O	100 mg
CoCl ₂ *6H ₂ O	190 mg
NiCl ₂ *6H ₂ O	24 mg
CuCl ₂ *2H ₂ O	2 mg
ZnSO ₄ *7H ₂ O	144 mg
Na ₂ MoO ₄ *2H ₂ O	36 mg

3.1.3 Analysis of ATP

Groundwater for ATP extraction analysis was collected in triplicate from each sample bottle and transferred into sterile 15 mL Falcon centrifuge tubes. Extraction and analysis of ATP concentrations were based on the methods by /Lundin et al. 1986, Lundin 2000/. ATP was extracted from 100 μ L aliquots of groundwater within an hour of collection using 100 μ L BS-buffer (BioThema ATP Biomass Kit HS, Sweden). After extraction, 100 μ L of the ATP extract was mixed with 400 μ L of HS-buffer (BioThema ATP Biomass Kit HS, Sweden) in a FB12/Sirius luminometer (Berthold, Germany). The total volume of groundwater in the sample then became 50 μ l. Prior to each sample measurement, light emission of the 400 μ L HS-buffer without sample addition was allowed to diminish to less than 50 relative light units per second (rlu/s) in the luminometer. After addition of the ATP extracted sample, light emission was immediately determined using FB/Sirius PC Software quick measurement (Berthold, Germany). To account for attenuating effects from the sample on the enzymatic reactions (e.g. salinity, dissolved metals, sulphide), and to calibrate the luminometer readings, 10 μ L of internal ATP-standard (0.1 μ mole/L) was added to the extracted sample in the luminometer and light emission was measured again. All light emission measurements were performed three times. The equation used to calculate ATP-concentration in the sample was based on the average of three measurements as follows:

$$\text{pmol ATP/sample} = \frac{I_{\text{smp}} - I_{\text{bkg}}}{I_{(\text{std} + \text{smp} - \text{bkg})} - I_{(\text{smp} - \text{bkg})}} \quad (\text{Equation 1})$$

Where:

- I*: light intensity measured as relative light units
- smp*: sample
- bkg*: background with the HS buffer
- std*: standard

The amount of ATP per ml groundwater was calculated as:

$$\text{amol/ml groundwater} = \text{pmol ATP/sample (from Equation 1)} \times SF \times DF \quad (\text{Equation 2})$$

Where:

- SF*: shift factor from pmol to amol = 10^6
- DF*: dilution factor to obtain amount of ATP per ml = 1,000/50

4 Execution

4.1 General

Sixteen sterile 1 L bottles were sent in advance to the drill site.

4.2 Preparations

The samples were collected by personnel working at the drill site in the morning and sent by mail to the laboratory in Göteborg. The laboratory was prepared to analyse the samples as soon as they arrived. The inoculations and ATP measurements were finalized at noon the same day of arrival.

Sampling was executed at different times as listed in Table 4-1.

Table 4-1. Sampling times.

Sampling	Date	Sampling point		P2T1	P2T2	P3T1	P3T2	P4T1	P4T2
		P1T1	P1T2						
KLX11A	051221	07.14	07.32	07.17	07.34	07.20	07.36	07.23	07.38
KLX11A	060111	06.20	06.40	06.22	06.42	06.24	06.44	06.26	06.46

4.3 Data handling/post processing

The numbers obtained are directly transferred to the results section, without post processing.

4.4 Analyses and interpretations

Samples for cultivation are diluted and distributed on nutrient medium agar dishes in triplets. The number of colonies is counted on all dilutions and parallels. The average of the triplet that lies between 30 and 300 colonies is taken as the value. This value should correspond well with the other triplets when the dilutions are taken into account.

The average ATP content of one living microbe in groundwater is about 10^{-18} mole. The ATP content can, therefore, be transferred to total amount of living microbes in the sample.

There is a general upper limit that should not be exceeded for the number of cultivable bacteria and ATP. Obviously, zero values would be best, but that is far from achievable under full scale field conditions. The simple recommendation is “the lower numbers the better”. Based on earlier experiences, a level of 1,000 cultivable bacteria per litre can easily be achieved if the system is kept clean. At some sites levels of 100 cultivable bacteria per litre or less have been achieved. The number 1,000 is, therefore, taken as the limit for approval of a clean flushing water system. A red line denotes this limit in the result Figures 5-1 and 5-2.

4.5 Nonconformities

None.

5 Results

5.1 KLX11A drilling

The numbers of cultivable cells in the flushing water was in most cases below the acceptable limit, i.e. 1,000 cells ml⁻¹, in December 2005 during drilling of KLX11A. At upstart of the drilling in January of KLX11A, the drill water system was cleaned. The numbers of cultivable cells were well below the limit of acceptance after this cleaning.

The ATP concentrations were about similar at both sampling occasions. ATP correlates with the total number of bacteria. It is consequently a measure of both contaminating microorganisms in the drill water system and naturally occurring cells in the drill water well. In one case, after uranin dosage in January, the ATP concentration was 10 times higher than the average. This indicates an erratic addition of many living cells. The most plausible explanation is that attached bacteria were sloughed off from tube walls or valve interior during sampling. That can give peaks in numbers in a single sample in a series. This is then more of a sampling effect that is very difficult to track the source of. As the ATP levels were comparable throughout 15 out of 16 analyses, it can be concluded that the drill water system, in general, did not add large amounts of contaminating cells to the drill water.

There was no clear effect from the UV unit on cultivable numbers and the ATP except for P2T1 in January 2006, when the numbers after the UV was only 6.7 cells ml⁻¹. Contradictory, in December 2005, the numbers of cultivable cells increased significantly after the UV unit compared to the drill water well. The source can be the several. It is not possible to rule out the efficiency of the UV based on this result. Samples just before and after the UV-unit will be needed to evaluate the efficiency of this unit.

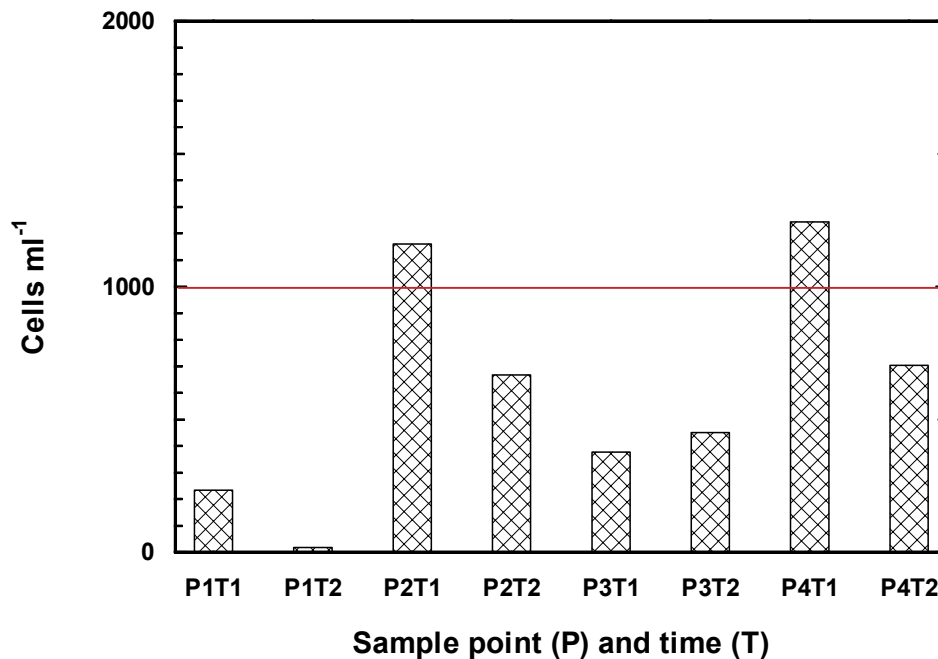

Figure 5-1. The number of cultivable bacteria in the flushing water system during drilling of KLX11A in December 2005 (051221). Sample points refer to Figure 1-1. Sampling times are given in Table 4-1.

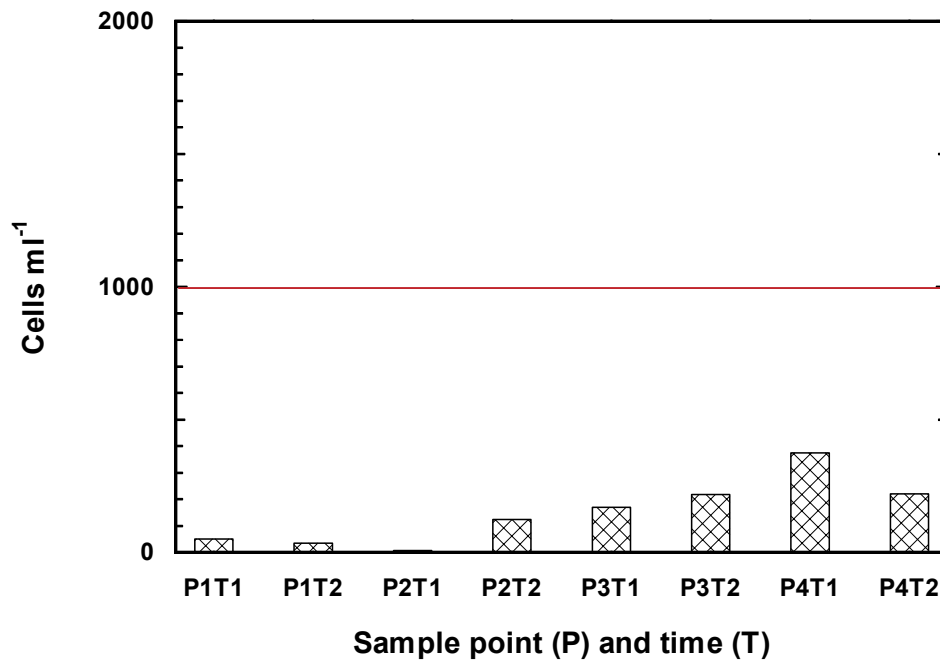

Figure 5-2. The number of cultivable bacteria in the flushing water system during drilling of KLX11A in January 2006 (051221). Sample points refer to Figure 1-1. Sampling times are given in Table 4-1.

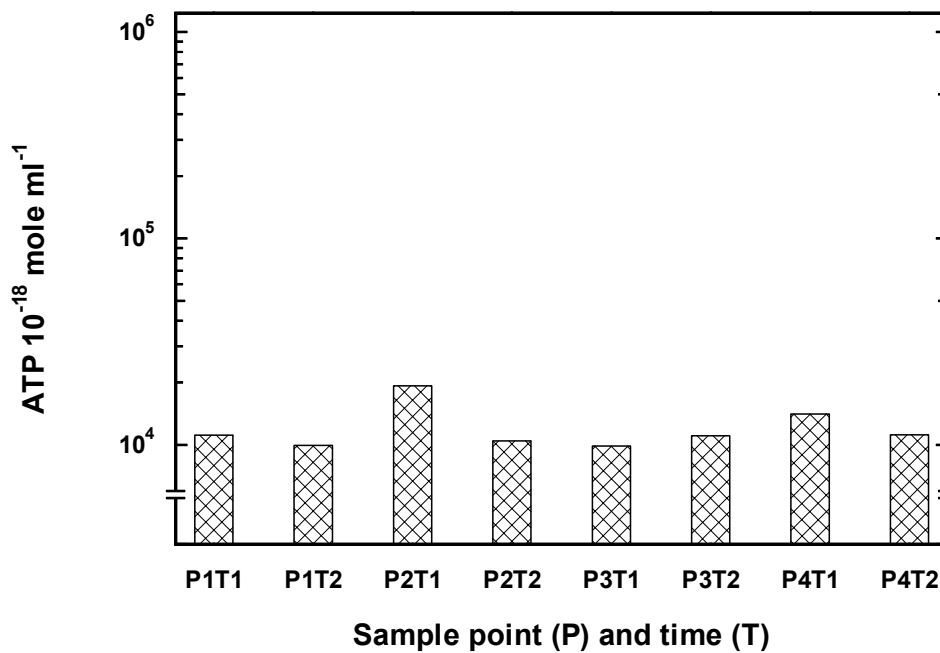

Figure 5-3. The concentration of ATP in the flushing water system during drilling of KLX11A in December 2005 (051221) Sample points refer to Figure 1-1. Sampling times are given in Table 4-1.

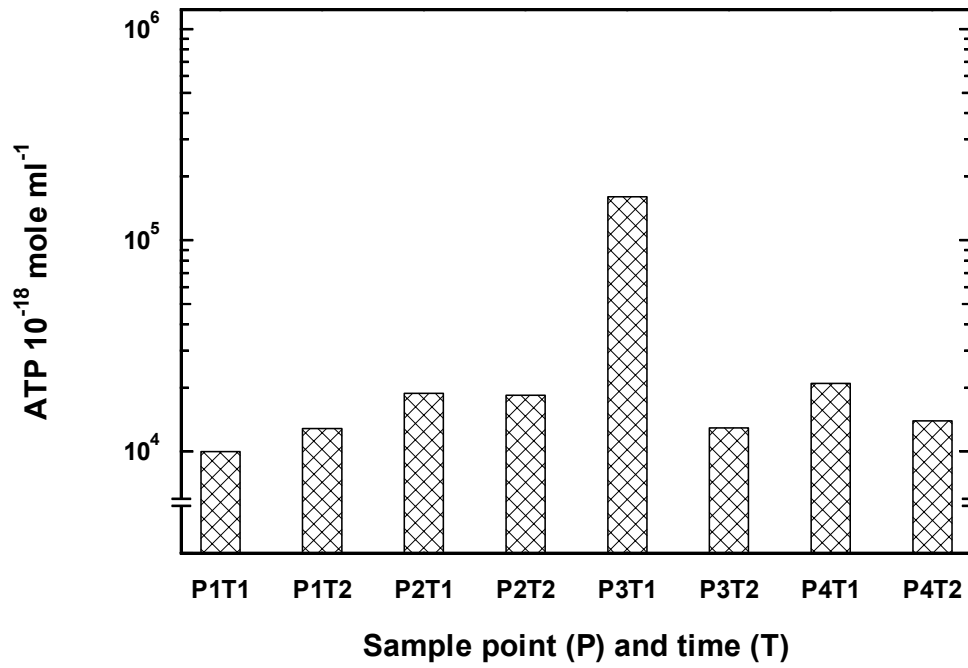

Figure 5-4. The concentration of ATP in the flushing water system during drilling of KLX11A in January 2006 (051221). Sample points refer to Figure 1-1. Sampling times are given in Table 4-1.

6 Conclusions

Earlier controls of the drill water system in Oskarshamn have revealed numbers of cultivable bacteria far above the limit for an acceptable system /Pedersen 2005ab/. This investigation, however, generally demonstrated values below unacceptable numbers. Both analyses dates showed much lower numbers than found earlier. The cleaning effort before start in January 2006 resulted in even lower numbers compared to the results from December 2005. The level of cultivable bacteria in January is excellent and should be kept.

References

- Lundin A, Hasenson M, Persson J, Pousette Å, 1986.** Estimation of biomass in growing cell lines by adenosine triphosphate assay. *Methods in Enzymology* 133, 27–42.
- Lundin A, 2000.** Use of firefly luciferase in ATP-related assays of biomass, enzymes and metabolites. *Methods in enzymology* 305, 346–370.
- Kalmus A, 2004.** Oskarshamn site investigation. Control of flushing water used for drilling 2003-11-25, pp 1–20. SKB P-04-32. Svensk Kärnbränslehantering AB.
- Pedersen K, Hallbeck L, Arlinger J, Erlandson A-C, Jahromi N, 1997.** Investigation of the potential for microbial contamination of deep granitic aquifers during drilling using 16S rRNA gene sequencing and culturing methods. *J Microbiol Methods* 30, 179–192.
- Pedersen K, Ekendahl S, 1990.** Distribution and activity of bacteria in deep granitic groundwaters of southeastern Sweden. *Microb. Ecol.* **20**, 37–52.
- Pedersen K, 2005a.** Oskarshamn site investigation. Control of microorganism content in flushing water used for drilling of KAV04 and KLX03. pp 1–15 SKB P-05-86. Svensk Kärnbränslehantering AB.
- Pedersen K, 2005b.** Oskarshamn site investigation. Control of microorganism content in flushing water used for drilling of KLX08. pp 1–15 SKB P-05-147. Svensk Kärnbränslehantering AB.